

## Tata Steel Technische Richtlijn

### R1 81 01 01 Flens montage procedure en aanhaalmoment tabellen

Auteur: L. van der Meulen / D. Jonker / M. Picavet  
Datum: 24-02-2024  
Versie: 2.1

De laatste versie van dit document is beschikbaar via:  
<https://www.tatasteeleurope.com/ts/nl/gezondheid-en-veiligheid/toegang-en-veiligheid-ijmuiden/voorschriften>

#### **Informatie en wijzigingen**

Inhoud document :  
Normalisatie:

MLE PTC MCE HPM  
ptc-adm@tatasteeleurope.com

+31 (0)251-496821

## Inhoudsopgave

INLEIDING .....	3
1 NORMEN .....	4
2 UITGANGSPUNTEN VOOR DE BEREKENING .....	4
3 MONTAGEPROCEDURE .....	5
3.1 Oppervlakteconditie van pakkingvlakken .....	5
3.2 Visuele inspectie voor montage.....	5
3.3 Smering en smeermiddelen.....	5
3.4 Het plaatsen en uitlijnen van de pakking.....	6
4 AANDRAAIEN EN OP MOMENT ZETTEN VAN DE BOUTEN.....	7
4.1 Algemeen.....	7
4.2 Gereedschap .....	7
4.3 Aanvullende eisen voor PTFE-pakkingen .....	8
4.4 Aanvullende eisen voor versterkte grafietpakkingen.....	8
4.5 Aanvullende eisen voor intern rubber beklede vlinderklep.....	8
4.6 Aanhaal procedure .....	9
5 DEMONTAGE .....	11
6 EISEN.....	11
6.1 Montage personeel.....	11
6.2 Kwaliteitsbewaking .....	11
7 FLENSPROTOCOL (voorbeeld/ sjabloon).....	12
8 AANHAALMOMENT TABELLEN.....	13
8.1 Tabel 1: Leidingspecificatie A010, A060, A061, A120, I010, I011, / PN10 – Grafietpakking..	13
8.2 Tabel 2: Leidingspecificatie A210, A211, A241, I200 / PN16 – Grafietpakking .....	14
8.3 Tabel 3: Leidingspecificatie A270, I250 / PN25 – Grafietpakking .....	15
8.4 Tabel 4: Leidingspecificatie A400, A401, A450 / PN40 – Grafietpakking .....	16
8.5 Tabel 5: Leidingspecificatie A420 / PN40 – Grafietpakking .....	17
8.6 Tabel 6: Leidingspecificatie F020, F022, H130 / PN10 – Grafietpakking.....	18
8.7 Tabel 7: Leidingspecificatie F210, F212 / PN16 – Grafietpakking .....	19
8.8 Tabel 8: Leidingspecificatie F250 / PN25 – Grafietpakking .....	20
8.9 Tabel 9: Leidingspecificatie F400, F401 / PN40 – Grafietpakking .....	21
8.10 Tabel 10: Leidingspecificatie M120, M170, M190 / PN10 – PTFE + wisselplaatpakking .....	22
8.11 Tabel 11: Leidingspecificatie M120, M170, M190 / PN10 – Topchem pakking .....	23
8.12 Tabel 12: Leidingspecificatie A010, A060, A061, A120, I010, I011 / PN10 – Vezelpakking ..	24
8.13 Tabel 13: Leidingspecificatie A210, A211, A241, I200 / PN16 – Vezelpakking.....	25
8.14 Tabel 14: Leidingspecificatie A400, A401, A450 / PN40 – Vezelpakking .....	26
8.15 Tabel 15: Leidingspecificatie F020, F022, H130 / PN10 – Vezelpakking .....	27
8.16 Tabel 16: Leidingspecificatie F210, F212 / PN16 – Vezelpakking.....	28
8.17 Tabel 17: Leidingspecificatie F400, F401 / PN40 – Vezelpakking.....	29
8.17 A Tabel 17a: Leidingspecificatie F400 / PN40 – Vezelpakking – Zuurstof systeem .....	30
8.17 B Tabel 17b: Leidingspecificatie F401 / PN40 – Vezelpakking – Zuurstof systeem .....	31
8.18 Tabel 18: Leidingspecificatie A060 / PN10 – PTFE-gebaseerde pakking .....	32
8.19 Tabel 19: Leidingspecificatie F020, F022 / PN10 – PTFE-gebaseerde pakking .....	33
8.20 Tabel 20: Leidingspecificatie F212 / PN16 – PTFE-gebaseerde pakking.....	34
8.21 Tabel 21: Leidingspecificatie M120, M170, M190 / PN10 – Hypalon pakking.....	35
8.22 Tabel 22: Leidingspecificatie A060, A120, I010, F020, F022 / PN10 – Rubber pakking .....	36
8.23 Tabel 23: Leidingspecificatie A060, A120, A210, I010, I200 / PN10/16 – Rubber pakking ...	37
8.24 Tabel 24: Leidingspecificatie F020, F022, F212, H130 / PN10/16 – Rubber pakking .....	38

## INLEIDING



Deze richtlijn is een aanvulling op de normen bedoeld voor leidingsystemen die gebaseerd zijn op DIN en EN. De relevante DIN - en EN-normen geven namelijk geen informatie over de kracht die kan worden uitgeoefend bij het maken van een flensverbinding tussen leidingflenzen.

Deze technische richtlijn bevat derhalve aanvullende gegevens en voorwaarden waaraan moet worden voldaan om een goede flensverbinding te maken.

Dit document omvat:



- Montageprocedure;
- Aandraaien van de bouten;
- Voorbeeld flensprotocol;
- Aanhaalmoment tabellen.



Dit document is niet bedoeld om tot een pakkingskeuze te komen. Zie daarvoor:

- R1850001 Pakking specificaties;
- R1850101 Toepassingsgebied en assortiment van pakkingen.

# 1 NORMEN

## EN-norm

EN 1092-1 Flenzen en hun verbindingen - Ronde flenzen voor buizen, afsluiters, hulpstukken en accessoires, PN-aanduiding - Deel 1: Stalen flenzen

EN 1591-1 Flenzen en hun verbindingen - Ontwerpregels voor flensverbindingen met ronde flenzen en pakkingen - Deel 1: Berekening

EN 1591-4 Ontwerpregels voor flensverbindingen met ronde flenzen en pakkingen - Deel 4: Kwalificatie van personeel dat geboute verbindingen in kritische drukkoudende systemen monteert



## Tatasteel-normen

- Tata Steel QHSE 5.30 Flensmanagement
- Tata Steel Standaard S1768101 Het markeren van medium dragers
- Tata Steel Richtlijn R1850001 Pakkingen
- Tata Steel Richtlijn R1420102 deel 2 Ontwerp van hydraulische- en pneumatische flensverbindingen
- VCA-certificaat WF (Werken aan flensverbindingen)
- VCA-certificaat WFpr (Werken aan flensverbindingen volgens protocol)

# 2 UITGANGSPUNTEN VOOR DE BEREKENING



- De berekening is uitgevoerd op basis van EN 1591-1 (versie 2014);
- Berekening is uitgevoerd met lektheid L0,01; betekent dat een specifieke lekkage klasse gelijk moet zijn aan of kleiner moet zijn dan 0,01 mgs-1m-1;
- Wrijvingscoëfficiënt toegepast in de berekening is 0,15 of 0,14 en daarna omgerekend naar ander smeermiddelen;
- Als basis voor de berekening van de aanhaalmomenten worden de flens-, pakking- en boutmaterialen gebruikt;
- Speciale materialen zoals nikkel, titanium, enz. zijn niet opgenomen in de aanhaalmomenten berekening, dit moet per situatie apart worden bekeken en beoordeeld;
- Pakkingsterkteparameters op basis van <http://www.gasketdata.org>;
- Tolerantie en corrosietoeslag worden niet in aanmerking genomen voor de aanhaalmomenten berekening;
- Bij de berekening van EN-flenzen is rekening gehouden met extra belastingen volgens EN 1092-1;
- De waarden in de aanhaalmoment tabellen zijn gebaseerd op aanvaardbare spannings waarden;
- De aanhaalmomenten voor FRP zijn gebaseerd op de standaard van de fabrikant.

## 3 MONTAGEPROCEDURE



Afhankelijk van de flenscategorie bepaald in QHSE 5.30 moet tijdens de flensassemblage een "flensprotocol" worden ingevuld. Zie hoofdstuk 7 voor een voorbeeld.



### 3.1 Oppervlakteconditie van pakkingvlakken

In het geval dat het flens pakkingvlak tijdelijk is afgedekt, bijvoorbeeld met een anticorrosieve coating, moet de coating vóór de montage worden verwijderd.



Wanneer pakkingen worden vervangen, moet erop worden gelet dat de oude pakking volledig van het pakkingvlak wordt verwijderd zonder het vlak te beschadigen.

### 3.2 Visuele inspectie voor montage

Er moet aandacht worden besteed aan het schoon, intact en vlak hebben van de flensvlakken. In het bijzonder mag er geen oppervlakteschade in de vorm van radiaal georiënteerde groeven optreden. In geval van twijfel moet de schade ter plaatse door een deskundige worden onderzocht en indien noodzakelijk moeten de flenzen worden vervangen. Hieronder de procedure vermeld:

- Bouten, moeren en ringen moeten schoon en intact zijn. Bijzondere aandacht moet worden besteed aan schroefdraad en glijdende oppervlakken;
- Bouten, moeren en ringen die tijdens de montage worden gedemonteerd, moeten worden vervangen door nieuwe, tenzij de bouten, ringen en moeren in zeer goede staat zijn om hergebruik mogelijk te maken;
- Controleer de materialen van de bouten en moeren voordat deze geïnstalleerd worden (bout- en moeridentificatiesymbolen zijn te vinden op de boutkop en moerkop);
- Vóór de montage moet de monteur de pakking controleren op juistheid en beschadigingen;
- De pakking moet schoon, intact, droog en vrij van vervuiling zijn;
- Vanuit de praktijk is het toegestaan om bij grote pakkingen spraylijm zeer dun aan te brengen op 4 kwadranten. Voor zuurstofsystemen is spraylijm niet toegestaan. Het aanbrengen van lijm, grafiet tape of montage pasta's is niet toegestaan;
- Gebruikte pakkingen mogen niet opnieuw worden gebruikt met uitzondering van rubberpakkingen zonder inlage;
- Alle te installeren pakkingen moeten vrij zijn van indrukkingen of andere afwijkingen. Vezel- en elastomeerpakkingen mogen tijdens de opslag niet langdurig worden blootgesteld aan UV-straling (zonlicht) of warmte. De instructies van de fabrikant moeten worden opgevolgd.



### 3.3 Smering en smeermiddelen

Om wrijvingskrachten te minimaliseren, moeten de contactoppervlakken van de bouten, moeren en ringen voorbehandeld worden met geschikte smeermiddelen voordat ze worden vastgedraaid. Optimale smering wordt bereikt wanneer alle contactoppervlakken, inclusief de schroefdraad- en moer, worden gesmeerd. Alleen op deze manier kan de vereiste voorklemkracht van de bouten worden bereikt.



In principe moeten alle smeermiddelen worden aangebracht in een dunne maar volledig bedekkende film. Het aanbrengen van te veel smeermiddel levert geen voordeel op met betrekking tot wrijvingsvermindering of anderszins. In de basis wordt molycote voorgeschreven als smeermiddel.



Voor zuurstofleidingwerk mogen alleen Berulub OX 40 EP of Berulub OX 100 EP als smeermiddel op de bouten en ringen worden gebruikt.

Als de boutverbindingen worden blootgesteld aan bedrijfstemperaturen > 250°C, moet hittebestendig smeermiddel worden aangebracht. Zorg ervoor dat het smeermiddel chemisch geschikt is voor de

bout, moer, ring én procesmedium. Dit vermijdt dat het smeermiddel kan bijdragen aan spanningscorrosie en of galvanische corrosie.

### 3.4 Het plaatsen en uitlijnen van de pakking

Pakkingen die worden gebruikt, moeten worden gemonteerd volgens de pakkingspecificatie behorende bij de specificatie van het leidingsysteem, isometrische tekening of beschrijving van het apparaat.

Synthetische vezelpakkingen mogen niet worden ingevet. Invetten heeft een negatief effect op de druksterkte en de gasdichtheid van de pakking. De pakking wordt geleverd met een antiplaklaag. De versterkte grafietpakking dienen tevens om de bovenstaande redenen in droge staat worden geïnstalleerd.



Voor een correcte montage van de flensverbindingen is het essentieel dat de flenzen parallel worden uitgelijnd, waardoor de pakking kan worden geplaatst zonder te beschadigen. Met name in het geval van verschraalde bouten moet een montagehulpmiddel kunnen worden aangebracht in de vorm van centreerpennen waardoor de pakking mooi gecentreerd is.

De afdichtingsvlakken moeten zo uit elkaar worden geschoven dat de pakking kan worden ingebracht zonder kracht uit te oefenen en zonder te beschadigen. Eventueel kan een flenzenspreider gebruikt worden.



Een goede uitlijning van alle onderdelen is essentieel om een maximaal afdichtingsoppervlak, maximale uniforme afdichtingsdruk en verminderde wrijving tussen de moer en de flens te garanderen.



De opening tussen de afdichtingsvlakken, nadat de bouten handvast zonder gereedschap zijn vastgezet maar voordat de bouten worden vastgedraaid met de momentsleutel, dient te worden gecontroleerd. De maximaal toelaatbare opening wordt weergegeven in onderstaande tabel.

De opening dient als eerst te worden hersteld aan de zijde waar deze het breedst is (a). Wanneer de afstand groter is dan in de tabel beschreven mag met maximaal 10% van het aanhaalmoment getracht worden de grootste afwijking binnen de tolerantie te krijgen.

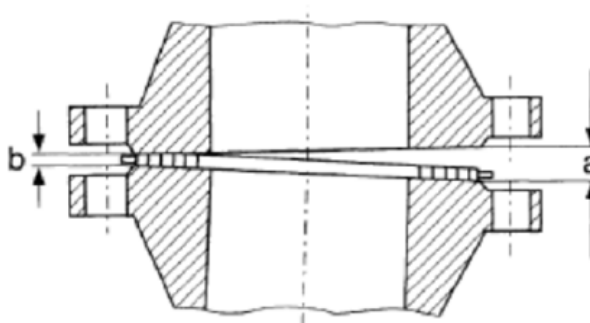

DN	a – b (mm)
10-150	± 0,5
> 150	± 1,0

Zie NEN EN 13480-4 Bijlage B

## 4 AANDRAAIEN EN OP MOMENT ZETTEN VAN DE BOUTEN







### 4.1 Algemeen

2.1

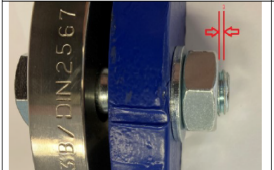
De volgorde waarin de bouten en moeren worden vastgedraaid is essentieel voor de verdeling van de krachten die op de pakking werken (vlaktedruk). Onjuist op moment zetten leidt tot een brede spreiding van de afdichtingsdruk en kan leiden tot een tekort aan de vereiste minimale vlaktedruk, waardoor lekkage ontstaat.

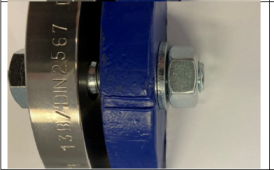
2.1

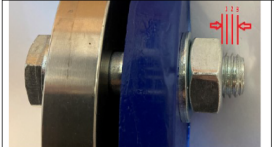
Nadat de moeren zijn vastgedraaid, moet de moerhoogte volledig dragen op de bout en minimaal 1 gang doorsteken. Het aanbevolen aantal gangen door de moer heen is 3.

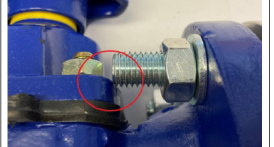
		De uitsteeklengte moet minimaal 1 draadgang zijn. Deze boutverbinding is <b>goedgekeurd</b> .			De uitsteeklengte is kleiner dan 1 draadgang. Deze boutverbinding is <b>afgekeurd</b> .
		Voorkeur is om de uitsteeklengte 3 draadgangen te geven. Deze boutverbinding is <b>goedgekeurd</b> .			Het buiten de moer uitstekende deel van de bout moet geheel vrij blijven. Deze boutverbinding is <b>afgekeurd</b> .

2.1

Er wordt op gelet dat de moer niet op borst van de bout vastloopt waardoor het aanhaalmoment wel bereikt wordt maar de juiste vlaktedruk niet.

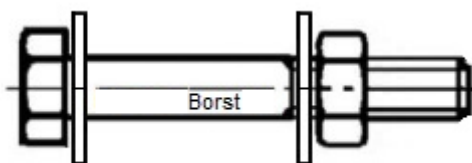

Draadstangen moeten zo worden gemonteerd dat het draad aan beide uiteinden ongeveer hetzelfde is. Boutkoppen, moeren en ringen moeten in hetzelfde vlak gemonteerd zijn. De bouten moeten met de hand worden geplaatst, met inachtneming van het volgende:

2.1

2.1

- Alle bouten, moeren en ringen dienen te worden gecontroleerd op beschadigingen;
- Alle bouten en moeren moeten handmatig zonder haperingen over elkaar heen draaien, bij twijfel moeten deze worden vervangen;
- Alle nieuw gemonteerde bouten, moeren en ringen dienen thermisch verzinkt zijn (volgens NEN EN ISO 10684). Tenzij anders aangegeven in de specificaties;
- Onder de moeren en boutkop moeten ringen volgens ISO 7089 of ISO 7090 worden gebruikt. De hardheid van de ringen moet ten minste klasse 200HV zijn;
- Installeer de bouten zodanig dat alle boutkoppen zich aan één kant van de flens bevinden;
- In het geval van schroefverbindingen waarbij de boutkop wordt gedraaid (blind getapt gat), plaatst u de ring onder de boutkop waarbij gelet wordt dat de bout niet tegen het eind loopt;
- Bij horizontaal gemonteerde flenzen, dienen de bouten van bovenaf te worden geplaatst;

### 4.2 Gereedschap

Om overmatige krachten op boutverbindingen bij het toepassen van de vereiste aanhaalwaarden te voorkomen, is het gebruik van gekalibreerde verstelbare momentsleutels vereist. De momentsleutels

mogen alleen op de moeren worden gebruikt. Het gebruik van niet instelbare elektrische of pneumatische slagmoersleutel of boutentol is verboden. Voor kritische verbindingen, bijvoorbeeld chloor, enz. wordt het gebruik van elektronische momentsleutels met aanhaalmoment indicator aanbevolen. Hydraulische aanhaalgereedschappen mogen alleen worden gebruikt na overleg met de voorman of PTC-MCE-HPM.

### 4.3 Aanvullende eisen voor PTFE-pakkingen

PTFE-pakkingen moeten opnieuw worden aangehaald om hun stressontspanningsgedrag te compenseren. Raadpleeg de leverancier van pakkingen voor gedetailleerde en specifieke informatie over het type pakking dat wordt gebruikt of de afdeling PTC MCE HPM. De gangbare praktijk is om na 24 uur de boutverbindingen weer na te halen bij procestemperatuur, met 70% van de aanhaalmomentwaarde.

### 4.4 Aanvullende eisen voor versterkte grafietpakkingen

Bij gebruik van versterkte grafietpakkingen moet de bout verbinding in drukloze toestand in één aanhaalprocedure worden vastgedraaid. Wanneer dit niet correct wordt gedaan, kan de pakking medium opzuigen en gaan de mechanische eigenschappen van de pakking verloren.

### 4.5 Aanvullende eisen voor intern rubber beklede vlinderklep

Bij gebruik van een met rubber beklede vlinderklep kan er gekozen worden de afdichting te maken met het rubber van de bekleding van de appendage. In dat geval zal de leverancier in zijn handleiding het toe te passen aanhaalmoment voorschrijven, bijvoorbeeld:

2.1



Aanhaalmoment.  
Tightening torque.  
Anzugmoment.  
Couple de serrage.

Totdat metaal-metaal contact ontstaat.  
Until metal touches the flange face.  
Bis Metall-Metall Kontakt entsteht.  
Jusqu'au contact métallique entre le corps de la vanne et la bride.

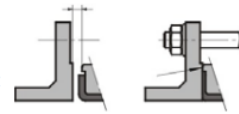



## 4.6 Aanhaal procedure

De bouten moeten in de volgende volgorde worden vastgedraaid:

1. Alle bouten/moeren/ringen moeten handvast zijn gemonteerd,
2. Bepaal de grootste opening (a) (zie afbeelding hieronder),
3. Bout nabij (a) is de eerste bout in de aanhaalcyclus,
4. KrUISlings zoals afgebeeld in de figuren op de volgende pagina's, tot 30% van het nominale koppel,
5. Gelijk aan 3 maar dan tot 60% van het nominale aanhaalmoment,
6. Gelijk aan 3 maar dan tot 100% van het nominale aanhaalmoment,
7. Nogmaals naar het volledige nominale koppel, met de klok mee.
8. Sequence 6. moet worden herhaald totdat de moeren niet verder draaien bij het aanbrengen van het volledige koppel.

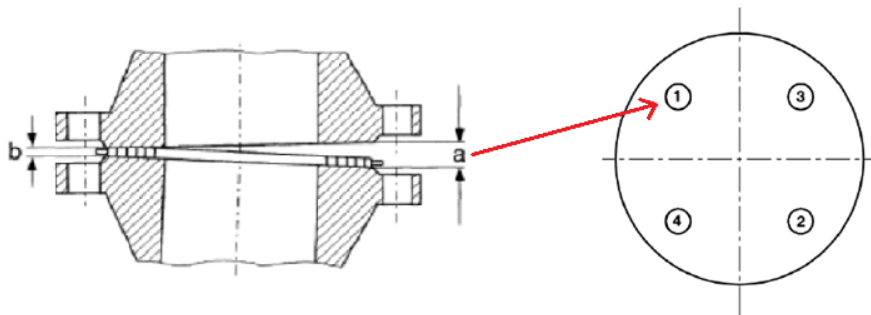

2.1

In individuele gevallen vereist de "relaxatie" van de pakking (de aanpassing van het pakkingsmateriaal aan het flensvlak) opnieuw aandraaien van bouten. In dergelijke gevallen moeten de bouten na enkele uren of na de eerste blootstelling aan hitte, bij kamertemperatuur opnieuw worden vastgedraaid in drukloze toestand van de flensverbinding. Een risicobeoordeling is vereist, indien het nahalen van de verbinding gedurende het in bedrijf zijn of bij een verhoogde temperatuur.

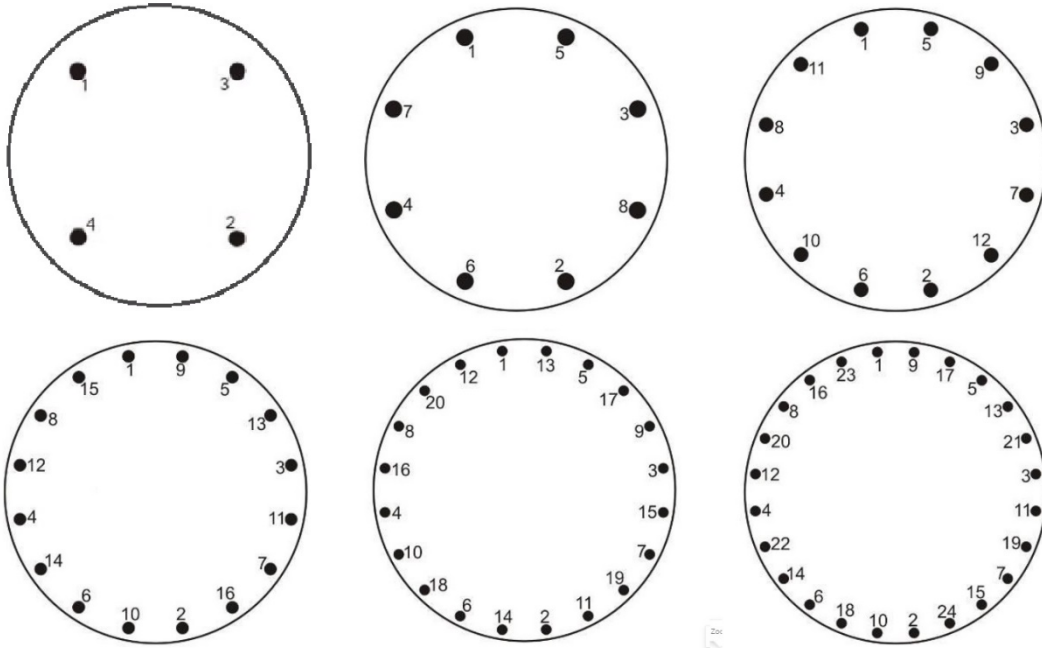

Volgordes van kruislings aanhalen, hoe groter de flens hoe complexer het wordt.

## 5 DEMONTAGE

Er moet voor worden gezorgd dat de installatie drukloos en indien noodzakelijk gespoeld is.



- Ingebouwde of aangebouwde onderdelen die niet apart gedemonteerd kunnen worden, moeten worden vastgezet voordat de flensverbinding wordt gedemonteerd;
- Het losdraaien van de bouten en/of moeren moet beginnen vanaf het verste punt van het lichaam af en dan de naastgelegen bouten met die verstande dat de bout het dichtste bij de monteur als laatste wordt gelost.
- Als de buis onder mechanische belasting staat, moet rekening worden gehouden met de mogelijkheid van plotselinge doorbuiging of verplaatsing;
- Wanneer pakkingen worden vervangen, moet ervoor worden gezorgd dat de oude pakking volledig van het pakkingvlak wordt verwijderd zonder het pakkingvlak van de flens te beschadigen.

## 6 EISEN



In QHSE 5.30 Flensbeheer wordt leidingwerk ingedeeld op basis van de PED en enkele uitzonderingen in flenscategorien. Afhankelijk van de flenscategorien kan de flensmonteur een certificaat aan een flensverbinding in leidingwerk werken. De verschillende certificaten kunnen zijn:

- VCA-WF (werken aan flensverbindingen),
- VCA-WFpr (werken aan flensverbindingen onder protocol)
- NEN-EN1591 Ontwerpregels voor flensverbindingen

### 6.1 Montage personeel



De montage van de flensverbindingen mag alleen worden uitgevoerd door gekwalificeerd (gecertificeerd) personeel. Het certificaat van de monteur bepaald aan welke leidingen de monteur mag werken.

### 6.2 Kwaliteitsbewaking



Uit de flenscategorie volgt welke kwaliteitsborgingsmaatregelen inclusief de relevante documentatie nodig zijn. Zie QHSE 5.30. Het afgetekende protocolformulier wordt geborgd in het databoek dat door de leverancier wordt opgeleverd. Indien er geen sprake is van een leverancier wordt het afgetekende protocolformulier geborgd in SAP.

## 7 FLENSPROTOCOL (voorbeeld/ sjabloon)

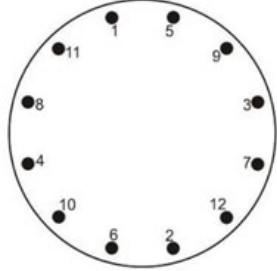
<b>Fabriek:</b>		
<b>Adrescode:</b>		
<b>Tag nummer:</b>		
<b>Flens:</b>	Grootte	DN___ PN__
<b>Pakking:</b>	Type	
	Hoeveelheid	
<b>Bout verbinding</b>	Boutmaat	Bout M___ x ___
	Aantal bouten	
	Hoeveelheid moeren	
	Aantal ringen	
	Smeermiddel:	
<b>Montageprocedure:</b>		
Stap 1:	___ Nm      Kruislings 30%	
Stap 2:	___ Nm      Kruislings 60%	
Stap 3:	___ Nm      Kruislings 100%	
Stap 4:	___ Nm      100% met de klok mee	
Stap 5:	___ Nm      100% met de klok mee	
<b>Montage</b>		<b>Opmerkingen:</b>
Leidingen uitgelijnd?	Ja / Nee	
Bouten draad schoon?	Ja / Nee	
Bouten ingevet?	Ja / Nee	
Ringen gebruikt?	Ja / Nee	
Momentsleutel gebruikt?	Ja / Nee	Gekalibreerd: [___/___]
Klep/instrument vernieuwd	Ja / Nee	
<b>Eindcontrole</b>		
Naam monteur:		
Naam bedrijf:		
Naam inspecteur:		
Datum:		

## 8 AANHAALMOMENT TABELLEN

### 8.1 Tabel 1: Leidingspecificatie A010, A060, A061, A120, I010, I011, / PN10 – Grafietpakking

			Table 1												
Pipe class			A060, A120, A061, A010, I011, I010												
Pipe system			PN10												
Flange Material			P250GH												
Bolt Material			25CrMo4 / 8.8												
Gasket Material			Novaphit SSTC TA-L / novaphit SSTC TA-L with XP-Technology 2mm												
Gasket Manufacture			Frenzelit												
Gasket type			IBC												
Leak tightness			L0.01												
Friction			0,15												
Design pressure			According to the pipe class												
Design Temperature			200°C considered in the calculation												
External force and moments			DN15 - DN350: according to EN1092 -1 (reduced) DN400 - DN500: 1,35 times of internal pressure DN600 & above: 1 times of internal pressure												
<b>Remarks</b>															
- Depending on lubrication, state of bolt and external forces the actual required torque may differ from the below advised calculated torque															
- Afhankelijk van de smering, staat van de bouten en externe krachten kan het werkelijk benodigde aanhaalmoment afwijken van het hieronder berekende aanhaalmoment															
Flange size (DN)	Bolt size	Number	External axial force (KN)	Bolt Force KN			Torque Nm								
				Min	Max	Used	Oil 0,15			Molycoat 0,08			No Lubrication 0,25		
				Min	Max	Used	Min	Max	Used	Min	Max	Used	Min	Max	Used
15	M12	4	13,6	21	104	84	12	62	50	6	33	27	20	103	83
20	M12	4	18,1	17	104	85	17	61	50	9	33	27	28	102	83
25	M12	4	22,6	38	103	85	22	60	50	12	32	27	37	100	83
32	M16	4	29	47	202	131	36	155	100	19	83	53	60	258	167
40	M16	4	36,2	62	201	131	47	154	100	25	82	53	78	257	167
50	M16	4	50	83	204	131	64	156	100	34	83	53	107	260	167
65	M16	8	58,8	123	336	261	47	129	100	25	69	53	78	215	167
80	M16	8	72,4	149	443	261	57	170	100	30	91	53	95	283	167
100	M16	8	100	180	468	261	69	179	100	37	95	53	115	298	167
125	M16	8	101,2	221	462	261	85	177	100	45	94	53	142	295	167
150	M20	8	122,5	247	609	515	120	296	250	64	158	133	200	493	417
200	M20	8	128	326	685	515	158	333	250	84	178	133	263	555	417
250	M20	12	158,1	387	999	772	125	324	250	67	173	133	208	540	417
300	M20	12	173,2	460	1051	772	149	340	250	79	181	133	248	567	417
350	M20	16	187,1	696	1236	1029	169	300	250	90	160	133	282	500	417
400	M24	16	143,5	747	1429	1042	215	412	300	115	220	160	358	687	500
450	M24	20	182,9	1020	1452	1302	235	335	300	125	179	160	392	558	500
500	M24	20	227,5	1329	1514	1389	306	349	320	163	186	171	510	582	533
600	M27	20	243,9	1590	1817	1652	414	473	430	221	252	229	690	788	717
700	M27	24	226,6	1632	2368	1983	354	514	430	189	274	229	590	857	717
800	M30	24	298,1	2133	2808	2454	521	686	600	278	366	320	868	1143	1000
900	M30	28	372,4	2535	3656	2863	531	766	600	283	409	320	885	1277	1000
1000	M33	28	416,5	3074	4082	3506	701	931	800	374	497	427	1168	1552	1333

## 8.2 Tabel 2: Leidingspecificatie A210, A211, A241, I200 / PN16 – Grafietpakking

Pipe class			A210, A211, A241, I200			Table 2									
Pipe system			PN16												
Flange Material			P250GH												
Bolt Material			25CrMo4 / 8.8												
Gasket Material			Novaphit SSTC TA-L / novaphit SSTC TA-L with XP-Technology 2mm												
Gasket Manufacture			Frenzelt												
Gasket type			IBC												
Leak tightness			L0.01												
Friction			0,15												
Design pressure			According to the pipe class												
Design Temperature			200°C considered in the calculation												
External force and moments			DN15 - DN1000: according EN1092 -1 (reduced)												
<b>Remarks</b>															
- Depending on lubrication, state of bolt and external forces the actual required torque may differ from the below advised calculated torque															
- Afhankelijk van de smering, staat van de bouten en externe krachten kan het werkelijk benodigde aanhaalmoment afwijken van het hieronder berekende aanhaalmoment															
Flange size (DN)	Bolt size	Number	External axial force (KN)	Bolt Force KN			Torque Nm								
				Min	Max	Used	Oil 0,15			Molycoat 0,08			No Lubrication 0,25		
							Min	Max	Used	Min	Max	Used	Min	Max	Used
15	M12	4	13,6	27	98	67	16	59	40	9	31	21	27	98	67
20	M12	4	18,1	43	93	67	26	56	40	14	30	21	43	93	67
25	M12	4	22,6	57	94	67	34	56	40	18	30	21	57	93	67
32	M16	4	29	70	188	128	54	146	100	29	78	53	90	243	167
40	M16	4	36,2	92	185	128	72	144	100	38	77	53	120	240	167
50	M16	4	45,3	115	190	154	90	148	120	48	79	64	150	247	200
65	M16	8	58,8	155	329	257	60	128	100	32	68	53	100	213	167
80	M16	8	72,4	191	431	257	74	168	100	39	90	53	123	280	167
100	M16	8	88,1	219	445	308	85	173	120	45	92	64	142	288	200
125	M16	8	101,2	272	432	308	106	168	120	57	90	64	177	280	200
150	M20	8	110,8	299	589	412	145	286	200	77	153	107	242	477	333
200	M20	12	128	394	774	618	128	251	200	68	134	107	213	418	333
250	M24	12	143,1	479	919	651	184	353	250	98	188	133	307	588	417
300	M24	12	173,2	615	1395	1042	236	536	400	126	286	213	393	893	667
350	M24	16	164,8	830	1736	1389	239	500	400	127	267	213	398	833	667
400	M27	16	176,1	954	1929	1537	310	628	500	165	335	267	517	1047	833
450	M27	20	186,8	1350	2029	1537	351	528	400	187	282	213	585	880	667
500	M30	20	196,9	1624	2175	1875	276	638	550	147	340	293	460	1063	917
600	M33	20	310,5	2309	3117	2504	738	996	800	394	531	427	1230	1660	1333
700	M33	24	319,6	2386	3272	2629	635	871	700	339	465	373	1058	1452	1167
800	M36	24	415,3	3128	3582	3281	906	1037	950	483	553	507	1510	1728	1583
900	M36	28	467,7	3692	4335	3828	916	1076	950	489	574	507	1527	1793	1583
1000	M39	28	520,6	4056	5670	4475	1088	1521	1200	580	811	640	1813	2535	2000

### 8.3 Tabel 3: Leidingspecificatie A270, I250 / PN25 – Grafietpakking

Pipe class	A270, I250	<b>Table 3</b>													
Pipe system	PN25														
Flange Material	P250GH														
Bolt Material	25CrMo4														
Gasket Material	Novaphit SSTC TA-L / novaphit SSTC TA-L with XP-Technology 2mm														
Gasket Manufacture	Frenzelit														
Gasket type	IBC														
Leak tightness	L0.01														
Friction	0,15														
Design pressure	According to the pipe class														
Design Temperature	200°C considered in the calculation														
External force and moments	DN15 - DN600: according EN1092 -1 (reduced)														

#### Remarks

- Depending on lubrication, state of bolt and external forces the actual required torque may differ from the below advised calculated torque

- Afhankelijk van de smering, staat van de bouten en externe krachten kan het werkelijk benodigde aanhaalmoment afwijken van het hieronder berekende aanhaalmoment

Flange size (DN)	Bolt size	Number	External axial force (KN)	Bolt Force KN			Torque Nm								
				Min	Max	Used	Oil 0,15			Molycoat 0,08			No Lubrication 0,25		
							Min	Max	Used	Min	Max	Used	Min	Max	Used
15	M12	4	13,6	27	98	67	16	59	40	9	31	21	27	98	67
20	M12	4	18,1	44	92	67	26	55	40	14	29	21	43	92	67
25	M12	4	25	59	93	67	35	56	40	19	30	21	58	93	67
32	M16	4	29	72	188	128	56	146	100	30	78	53	93	243	167
40	M16	4	36,2	92	185	128	72	144	100	38	77	53	120	240	167
50	M16	4	45,3	115	185	128	90	144	100	48	77	53	150	240	167
65	M16	8	58,8	156	415	257	61	162	100	33	86	53	102	270	167
80	M16	8	72,4	194	404	257	76	157	100	41	84	53	127	262	167
100	M20	8	88,1	251	601	412	122	292	200	65	156	107	203	487	333
125	M24	8	101,2	295	751	521	170	433	300	91	231	160	283	722	500
150	M24	8	110,8	382	997	694	220	574	400	117	306	213	367	957	667
200	M24	12	128	527	1282	1042	202	492	400	108	262	213	337	820	667
250	M27	12	143,1	645	1489	1153	280	646	500	149	345	267	467	1077	833
300	M27	16	152,5	838	1752	1230	273	570	400	146	304	213	455	950	667
350	M30	16	164,8	945	2325	1636	347	853	600	185	455	320	578	1422	1000
400	M33	16	176,1	1087	2810	2003	434	1122	800	231	598	427	723	1870	1333
450	M33	20	186,8	1056	3090	2504	337	987	800	180	526	427	562	1645	1333
500	M33	20	206,7	1224	4178	2504	391	1335	800	209	712	427	652	2225	1333
600	M36	20	273,5	1415	4367	2878	492	1517	1000	262	809	533	820	2528	1667

#### 8.4 Tabel 4: Leidingspecificatie A400, A401, A450 / PN40 – Grafietpakking

		Table 4													
Pipe class		A400, A401, A450													
Pipe system		PN40													
Flange Material		P250GH													
Bolt Material		25CrMo4 / 8.8													
Gasket Material		Novaphit SSTC TA-L / novaphit SSTC TA-L with XP-Technology 2mm													
Gasket Manufacture		Frenzelit													
Gasket type		IBC													
Leak tightness		L0.01													
Friction		0,15													
Design pressure		According to the pipe class													
Design Temperature		200°C considered in the calculation													

External force and moments DN15 - DN600: according EN1092 -1 (reduced)

#### Remarks

- Depending on lubrication, state of bolt and external forces the actual required torque may differ from the below advised calculated torque

- Afhankelijk van de smering, staat van de bouten en externe krachten kan het werkelijk benodigde aanhaalmoment afwijken van het hieronder berekende aanhaalmoment

Flange size (DN)	Bolt size	Number	External axial force (KN)	Bolt Force KN			Torque Nm								
				Min	Max	Used	Oil 0,15			Molycoat 0,08			No Lubrication 0,25		
							Min	Max	Used	Min	Max	Used	Min	Max	Used
15	M12	4	13,6	37	98	67	22	59	40	12	31	21	37	98	67
20	M12	4	18,1	59	91	67	35	54	40	19	29	21	58	90	67
25	M12	4	22,6	79	92	84	47	55	50	25	29	27	78	92	83
32	M16	4	29	98	188	128	76	146	100	41	78	53	127	243	167
40	M16	4	36,2	125	185	154	97	144	120	52	77	64	162	240	200
50	M16	4	45,3	160	184	167	125	143	130	67	76	69	208	238	217
65	M16	8	58,8	207	421	308	81	164	120	43	87	64	135	273	200
80	M16	8	72,4	256	411	308	100	160	120	53	85	64	167	267	200
100	M20	8	88,1	300	592	412	146	288	200	78	154	107	243	480	333
125	M24	8	101,2	361	740	521	208	426	300	111	227	160	347	710	500
150	M24	8	110,8	441	964	694	254	555	400	135	296	213	423	925	667
200	M27	12	128	629	1394	922	273	605	400	146	323	213	455	1008	667
250	M30	12	143,1	841	2052	1432	411	1003	700	219	535	373	685	1672	1167
300	M30	16	152,5	1026	2627	1909	376	963	700	201	514	373	627	1605	1167
350	M33	16	164,8	1011	2959	2003	404	1182	800	215	630	427	673	1970	1333
400	M36	16	180,5	1458	4294	2993	633	1865	1300	338	995	693	1055	3108	2167
450	M36	20	230,6	1519	4668	3741	528	1622	1300	282	865	693	880	2703	2167
500	M39	20	291	1763	5417	3995	662	2034	1500	353	1085	800	1103	3390	2500
600	M45	20	394,4	2253	7396	5466	989	3248	2400	527	1732	1280	1648	5413	4000



## 8.5 Tabel 5: Leidingspecificatie A420 / PN40 – Grafietspakking

			Table 5													
Pipe class			A420													
Pipe system			PN40													
Flange Material			16Mo3													
Bolt Material			21CrMoV5-7													
Gasket Material			Novaphit SSTC TA-L / novaphit SSTC TA-L with XP-Technology 2mm													
Gasket Manufacture			Frenzellit													
Gasket type			IBC													
Leak tightness			L0.01													
Friction			0,15													
Design pressure			According to the pipe class													
Design Temperature			200°C considered in the calculation													
External force and moments			DN25 - DN600: according EN1092 -1 (reduced)													
<b>Remarks</b>																
- Depending on lubrication, state of bolt and external forces the actual required torque may differ from the below advised calculated torque																
- Afhankelijk van de smering, staat van de bouten en externe krachten kan het werkelijk benodigde aanhaalmoment afwijken van het hieronder berekende aanhaalmoment																
Flange size (DN)	Bolt size	Number	External axial force (KN)	Bolt Force KN			Torque Nm									
				Min	Max	Used	Oil 0,15			Molycoat 0,08			No Lubrication 0,25			
							Min	Max	Used	Min	Max	Used	Min	Max	Used	
15	M12	4														
20	M12	4														
25	M12	4	25	82	109	92	49	65	55	26	35	29	82	108	92	
32	M16	4	32	101	220	154	79	171	120	42	91	64	132	285	200	
40	M16	4	40	130	223	180	101	174	140	54	93	75	168	290	233	
50	M16	4	50	166	218	180	129	170	140	69	91	75	215	283	233	
65	M16	8	58,8	209	419	308	81	163	120	43	87	64	135	272	200	
80	M16	8	80	261	491	360	102	191	140	54	102	75	170	318	233	
100	M20	8	100	309	726	515	150	353	250	80	188	133	250	588	417	
125	M24	8	111,8	367	885	694	211	510	400	113	272	213	352	850	667	
150	M24	8	122,5	447	1069	781	257	616	450	137	329	240	428	1027	750	
200	M27	12	141,4	661	1535	1153	287	666	500	153	355	267	478	1110	833	
250	M30	12	158,1	868	2254	1636	424	1102	800	226	588	427	707	1837	1333	
300	M30	16	164,9	1282	2811	2182	470	1031	800	251	550	427	783	1718	1333	
350	M33	16	178,1	1409	3133	2003	563	1251	800	300	667	427	938	2085	1333	
400	M36	16	195,2	2534	4728	3454	1101	2053	1500	587	1095	800	1835	3422	2500	
450	M36	20	249,3	2656	4902	4029	923	1703	1400	492	908	747	1538	2838	2333	
500	M39	20	314,6	2969	5760	4262	1115	2163	1600	595	1154	853	1858	3605	2667	
600	M45	20	426,4	4381	7718	5693	1924	3389	2500	1026	1807	1333	3207	5648	4167	

## 8.6 Tabel 6: Leidingspecificatie F020, F022, H130 / PN10 – Grafietpakking

Pipe class			F020, F022, H130			Table 6									
Pipe system			PN10												
Flange Material			1.4404 / 1.4539 / 1.4571												
Bolt Material			A4-70												
Gasket Material			Novaphit SSTC TA-L / novaphit SSTC TA-L with XP-Technology 2mm												
Gasket Manufacture			Frenzelit												
Gasket type			IBC												
Leak tightness			L0.01												
Friction			0,15												
Design pressure			According to the pipe class												
Design Temperature			200°C considered in the calculation												
External force and moments			DN15 - DN600: according EN1092 -1 (reduced)												
Remarks															
- Depending on lubrication, state of bolt and external forces the actual required torque may differ from the below advised calculated torque															
- Afhankelijk van de smering, staat van de bouten en externe krachten kan het werkelijk benodigde aanhaalmoment afwijken van het hieronder berekende aanhaalmoment															
Flange size (DN)	Bolt size	Number	External axial force (KN)	Bolt Force KN			Torque Nm								
				Min	Max	Used	Oil 0,15			Molycoat 0,08			No Lubrication 0,25		
							Min	Max	Used	Min	Max	Used	Min	Max	Used
15	M12	4	11,8	22	115	67	13	69	40	7	37	21	22	115	67
20	M12	4	15,7	31	102	67	19	61	40	10	33	21	32	102	67
25	M12	4	19,6	40	102	67	24	61	40	13	33	21	40	102	67
32	M16	4	25,1	48	203	128	37	158	100	20	84	53	62	263	167
40	M16	4	31,4	63	193	128	49	150	100	26	80	53	82	250	167
50	M16	4	39,3	83	199	128	65	155	100	35	83	53	108	258	167
65	M16	8	51,1	123	271	180	48	105	70	26	56	37	80	175	117
80	M16	8	62,9	151	402	257	59	156	100	31	83	53	98	260	167
100	M16	8	78,6	181	437	257	70	170	100	37	91	53	117	283	167
125	M16	8	87,8	222	454	257	86	177	100	46	94	53	143	295	167
150	M20	8	96,2	250	548	412	121	266	200	65	142	107	202	443	333
200	M20	8	111,1	329	711	515	160	345	250	85	184	133	267	575	417
250	M20	12	124,2	390	894	618	126	290	200	67	155	107	210	483	333
300	M20	12	136,1	471	975	772	153	316	250	82	169	133	255	527	417
350	M20	16	147	706	1096	823	171	266	200	91	142	107	285	443	333
400	M24	16	157,1	838	1244	1042	241	358	300	129	191	160	402	597	500
450	M24	20	166,7	910	1295	1085	210	298	250	112	159	133	350	497	417
500	M24	20	175,7	1032	1389	1085	238	320	250	127	171	133	397	533	417
600	M27	20	192,5	1236	1612	1345	322	420	350	172	224	187	537	700	583

## 8.7 Tabel 7: Leidingspecificatie F210, F212 / PN16 – Grafietspakking

			Table 7												
Pipe class			F210, F212												
Pipe system			PN16												
Flange Material			1.4307 / 1.4571												
Bolt Material			A4-70												
Gasket Material			Novaphit SSTC TA-L / novaphit SSTC TA-L with XP-Technology 2mm												
Gasket Manufacture			Frenzelit												
Gasket type			IBC												
Leak tightness			L0.01												
Friction			0,15												
Design pressure			According to the pipe class												
Design Temperature			200°C considered in the calculation												
External force and moments			DN15 - DN600: according EN1092 -1 (reduced)												
<b>Remarks</b>															
- Depending on lubrication, state of bolt and external forces the actual required torque may differ from the below advised calculated torque															
- Afhankelijk van de smering, staat van de bouten en externe krachten kan het werkelijk benodigde aanhaalmoment afwijken van het hieronder berekende aanhaalmoment															
Flange size (DN)	Bolt size	Number	External axial force (KN)	Bolt Force KN			Torque Nm								
				Min	Max	Used	Oil 0,15			Molycoat 0,08			No Lubrication 0,25		
							Min	Max	Used	Min	Max	Used	Min	Max	Used
15	M12	4	11,8	27	115	67	16	69	40	9	37	21	27	115	67
20	M12	4	15,7	46	102	67	28	61	40	15	33	21	47	102	67
25	M12	4	19,6	60	102	84	36	61	50	19	33	27	60	102	83
32	M16	4	25,1	73	203	128	57	158	100	30	84	53	95	263	167
40	M16	4	31,4	92	193	128	72	150	100	38	80	53	120	250	167
50	M16	4	39,3	115	199	167	90	155	130	48	83	69	150	258	217
65	M16	8	51,1	154	265	206	60	103	80	32	55	43	100	172	133
80	M16	8	62,9	189	396	257	74	154	100	39	82	53	123	257	167
100	M16	8	78,6	226	424	257	88	165	100	47	88	53	147	275	167
125	M16	8	87,8	280	462	334	109	180	130	58	96	69	182	300	217
150	M20	8	96,2	311	538	412	151	261	200	81	139	107	252	435	333
200	M20	12	111,1	413	704	463	134	228	150	71	122	80	223	380	250
250	M24	12	124,2	483	839	651	185	322	250	99	172	133	308	537	417
300	M24	12	136,1	600	1179	781	230	453	300	123	242	160	383	755	500
350	M24	16	147	739	1662	1042	213	479	300	114	255	160	355	798	500
400	M27	16	157,1	831	1861	1230	270	605	400	144	323	213	450	1008	667
450	M27	20	166,7	934	1969	1537	243	512	400	130	273	213	405	853	667
500	M30	20	175,7	1090	2108	1534	320	618	450	171	330	240	533	1030	750
600	M33	20	244	1543	2701	1878	493	863	600	263	460	320	822	1438	1000

## 8.8 Tabel 8: Leidingspecificatie F250 / PN25 – Grafietpakking

Pipe class			F250	<b>Table 8</b>												
Pipe system			PN25													
Flange Material			1,4404													
Bolt Material			A4-70													
Gasket Material			Novaphit SSTC TA-L / novaphit SSTC TA-L with XP-Technology 2mm (Rev. 2)													
Gasket Manufacture			Frenzelit													
Gasket type			IBC													
Leak tightness			L0.01													
Friction			0,15													
Design pressure			According to the pipe class													
Design Temperature			200°C considered in the calculation													
External force and moments			DN15 - DN600: according EN1092 -1 (reduced)													
<b>Remarks</b>																
- Depending on lubrication, state of bolt and external forces the actual required torque may differ from the below advised calculated torque																
- Afhankelijk van de smering, staat van de bouten en externe krachten kan het werkelijk benodigde aanhaalmoment afwijken van het hieronder berekende aanhaalmoment																
Flange size (DN)	Bolt size	Number	External axial force (KN)	Bolt Force KN			Torque Nm									
				Min	Max	Used	Oil 0,15			Molycoat 0,08			No Lubrication 0,25			
							Min	Max	Used	Min	Max	Used	Min	Max	Used	
15	M12	4	11,8	27	115	67	16	69	40	9	37	21	27	115	67	
20	M12	4	15,7	46	102	67	28	61	40	15	33	21	47	102	67	
25	M12	4	19,6	60	102	84	36	61	50	19	33	27	60	102	83	
32	M16	4	25,1	73	203	128	57	158	100	30	84	53	95	263	167	
40	M16	4	31,4	92	193	128	72	150	100	38	80	53	120	250	167	
50	M16	4	39,3	115	197	167	90	153	130	48	82	69	150	255	217	
65	M16	8	51,1	162	397	257	63	155	100	34	83	53	105	258	167	
80	M16	8	62,9	195	440	257	76	171	100	41	91	53	127	285	167	
100	M20	8	78,6	244	573	412	119	278	200	63	148	107	198	463	333	
125	M24	8	87,8	289	696	521	166	401	300	89	214	160	277	668	500	
150	M24	8	96,2	320	918	694	184	529	400	98	282	213	307	882	667	
200	M24	12	111,1	414	1150	781	159	442	300	85	236	160	265	737	500	
250	M27	12	124,2	497	1412	1037	216	612	450	115	326	240	360	1020	750	
300	M27	16	136,1	607	1710	1230	197	556	400	105	297	213	328	927	667	
350	M30	16	147	756	2247	1636	277	824	600	148	439	320	462	1373	1000	
400	M33	16	157,1	868	2699	2003	347	1078	800	185	575	427	578	1797	1333	
450	M33	20	166,7	961	2928	2191	307	935	700	164	499	373	512	1558	1167	
500	M33	20	184,4	1135	3955	2817	363	1264	900	194	674	480	605	2107	1500	
600	M36	20	244	1393	4101	2878	484	1426	1000	258	761	533	807	2377	1667	

## 8.9 Tabel 9: Leidingspecificatie F400, F401 / PN40 – Grafietspakking

			Table 9												
Pipe class			F400, F401												
Pipe system			PN40												
Flange Material			1.4404 / 1.4571												
Bolt Material			21CrMo5-7 / A4-70												
Gasket Material			Novaphit SSTC TA-L / novaphit SSTC TA-L with XP-Technology 2mm												
Gasket Manufacture			Frenzelit												
Gasket type			IBC												
Leak tightness			L0.01												
Friction			0,15												
Design pressure			According to the pipe class												
Design Temperature			200°C considered in the calculation												
External force and moments			DN15 - DN400: according EN1092 -1 (reduced)												
<b>Remarks</b>															
- Depending on lubrication, state of bolt and external forces the actual required torque may differ from the below advised calculated torque															
- Afhankelijk van de smering, staat van de bouten en externe krachten kan het werkelijk benodigde aanhaalmoment afwijken van het hieronder berekende aanhaalmoment															
Flange size (DN)	Bolt size	Number	External axial force (KN)	Bolt Force KN			Torque Nm								
				Min	Max	Used	Oil 0,15			Molycoat 0,08			No Lubrication 0,25		
							Min	Max	Used	Min	Max	Used	Min	Max	Used
15	M12	4	11,8	34	113	67	20	68	40	11	36	21	33	113	67
20	M12	4	15,7	56	91	67	33	54	40	18	29	21	55	90	67
25	M12	4	19,6	75	98	84	45	59	50	24	31	27	75	98	83
32	M16	4	25,1	93	205	128	72	160	100	38	85	53	120	267	167
40	M16	4	31,4	124	197	154	97	153	120	52	82	64	162	255	200
50	M16	4	39,3	157	196	167	122	153	130	65	82	69	203	255	217
65	M16	8	19,7	184	318	257	72	124	100	38	66	53	120	207	167
80	M16	8	62,9	249	364	283	97	142	110	52	76	59	162	237	183
100	M20	8	78,6	294	416	329	143	202	160	76	108	85	238	337	267
125	M24	8	87,8	342	538	434	197	310	250	105	165	133	328	517	417
150	M24	8	96,2	418	749	521	241	431	300	129	230	160	402	718	500
200	M27	12	111,1	598	1059	807	259	459	350	138	245	187	432	765	583
250	M30	12	124,2	784	1571	1227	383	768	600	204	410	320	638	1280	1000
300	M30	16	136,1	965	2053	1636	354	753	600	189	402	320	590	1255	1000
350	M33	16	160,4	1239	2721	2003	495	1087	800	264	580	427	825	1812	1333
400	M36	16	161	1591	3498	2302	691	1519	1000	369	810	533	1152	2532	1667

## 8.10 Tabel 10: Leidingspecificatie M120, M170, M190 / PN10 – PTFE + wisselplaatpakking

Pipe class			M120, M170, M190	Table 10											
Pipe system			PN10												
Flange Material			PVDF/FRP, PP/FRP, PVC-U/FRP												
Bolt Material			4.6 HDG												
Gasket Material			VSP Pita gasket												
Gasket Manufacture			VSP/ Klinger												
Gasket type			IBC												
Leak tightness			L0.01												
Friction			0,14												
Design pressure			7 barg												
Design Temperature			95°C considered in the calculation												
External force and moments			DN15 - DN600: according EN1092 -1 (reduced)												
<b>Remarks</b>															
- Depending on lubrication, state of bolt and external forces the actual required torque may differ from the below advised calculated torque															
- Afhankelijk van de smering, staat van de bouten en externe krachten kan het werkelijk benodigde aanhaalmoment afwijken van het hieronder berekende moment															
- Maximum torque is based on flange material, if you feel or hear cracking of the flange stop and consult the TATA contact person															
- If more than 2 gaskets are used in one bolt assembly retorquing is required; to be advised by supplier/ PTC-HPM															
Flange size (DN)	Bolt size	Number	External axial force	Bolt Force KN			Torque Nm								
				Min	Max	Used	Copper grease 0,14			Molycoat 0,08			No Lubrication 0,25		
							Min	Max	Used	Min	Max	Used	Min	Max	Used
15	M12	4													
20	M12	4													
25	M12	4				39			20						
32	M16	4													
40	M16	4				59			40						
50	M16	4				59			40						
65	M16	8				66			45						
80	M16	8				132			45						
100	M16	8				132			45						
125	M16	8				147			50						
150	M20	8				141			60						
200	M20	8				141			60						
250	M20	12				247			70						
300	M20	12				265			75						
350	M20	16				353			75						
400	M24	16				412			105						
450	M24	20													
500	M24	20				515			105						

### 8.11 Tabel 11: Leidingspecificatie M120, M170, M190 / PN10 – Topchem pakking

Tabel nog niet beschikbaar. Neem voor meer informatie contact op met de pakkingleverancier.

## 8.12 Tabel 12: Leidingspecificatie A010, A060, A061, A120, I010, I011 / PN10 – Vezelpakking

Pipe class			A060, A120, A061, A010, I011, I010			Table 12									
Pipe system			PN10												
Flange Material			P250GH												
Bolt Material			25CrMo4 / 8.8												
Gasket Material			KLINGERSIL C-4400 2mm												
Gasket Manufacture			KLINGER® GmbH & Co. KG												
Gasket type			IBC												
Leak tightness			L0.01												
Friction			0,15												
Design pressure			According to the pipe class												
Design Temperature			200°C considered in the calculation												
External force and moments			DN15 -- DN350 = according EN1092 -1 (reduced) DN400 -DN500 - 1.35 times of internal pressure DN600 & above - 1 times of internal pressure												
Remarks															
- Depending on lubrication, state of bolt and external forces the actual required torque may differ from the below advised calculated torque															
- Afhankelijk van de smering, staat van de bouten en externe krachten kan het werkelijk benodigde aanhaalmoment afwijken van het hieronder berekende aanhaalmoment															
Flange size (DN)	Bolt size	Number	External axial force (KN)	Bolt Force KN			Torque Nm								
				Min	Max	Used	Oil 0,15			Molycoat 0,08			No Lubrication 0,25		
							Min	Max	Used	Min	Max	Used	Min	Max	Used
15	M12	4	13,6	68	121	84	40	72	50	21	38	27	67	120	83
20	M12	4	18,1	74	124	85	43	73	50	23	39	27	72	122	83
25	M12	4	22,6	92	119	103	54	70	60	29	37	32	90	117	100
32	M16	4	29	108	229	196	83	175	150	44	93	80	138	292	250
40	M16	4	36,2	135	230	196	103	176	150	55	94	80	172	293	250
50	M16	4	45,3	160	236	196	123	181	150	66	97	80	205	302	250
65	M16	8	58,8	172	420	313	66	161	120	35	86	64	110	268	200
80	M16	8	72,4	208	482	392	80	185	150	43	99	80	133	306	250
100	M16	8	90,5	255	488	392	98	187	150	52	100	80	163	312	250
125	M16	8	101,2	280	488	392	107	187	150	57	100	80	178	312	250
150	M20	8	122,5	345	695	515	168	338	250	90	180	133	280	563	417
200	M20	8	128	398	695	515	193	338	250	103	180	133	322	563	417
250	M20	12	143,1	461	1040	772	149	337	250	79	180	133	248	562	417
300	M20	12	156,8	544	1051	772	176	340	250	94	181	133	293	567	417
350	M20	16	169,3	814	1328	1029	198	323	250	106	172	133	330	538	417
400	M24	16	135,4	868	1525	1042	250	439	300	133	234	160	417	732	500
450	M24	20	182,9	1111	1545	1302	256	356	300	137	190	160	427	593	500
500	M24	20	227,5	1356	1603	1389	312	369	320	166	197	171	520	615	533
600	M27	20	196,8	1614	1908	1652	420	497	430	224	265	229	700	828	717
700	M27	24	203,9	1713	2458	1983	372	533	430	198	284	229	620	888	717
800	M30	24	298,1	2159	2882	2454	528	705	600	262	376	320	880	1175	1000
900	M30	28	335,2	2573	3733	2863	539	782	600	287	417	320	898	1303	1000
1000	M33	28	416,5	3097	4144	3506	707	946	800	377	505	427	1178	1577	1333



### 8.13 Tabel 13: Leidingspecificatie A210, A211, A241, I200 / PN16 – Vezelpakking

Pipe class	A210, A211, A241, I200
Pipe system	PN16
Flange Material	P250GH
Bolt Material	25CrMo4 / 8.8
Gasket Material	KLINGERSIL C-4400 2mm
Gasket Manufacture	KLINGER® GmbH & Co. KG
Gasket type	IBC
Leak tightness	L0.01
Friction	0,15
Design pressure	According to the pipe class
Design Temperature	200°C considered in the calculation
External force and moments	DN15 -- DN1000 = according EN1092 -1 (reduced)

#### Remarks

- Depending on lubrication, state of bolt and external forces the actual required torque may differ from the below advised calculated torque

- Afhankelijk van de smering, staat van de bouten en externe krachten kan het werkelijk benodigde aanhaalmoment afwijken van het hieronder berekende aanhaalmoment

Flange size (DN)	Bolt size	Number	External axial force (KN)	Bolt Force KN			Torque Nm								
				Min	Max	Used	Oil 0,15			Molycoat 0,08			No Lubrication 0,25		
							Min	Max	Used	Min	Max	Used	Min	Max	Used
15	M12	4	13,6	82	115	100	49	69	60	26	37	32	82	115	100
20	M12	4	20	83	113	100	50	68	60	27	36	32	83	113	100
25	M12	4	22,6	77	107	100	46	64	60	25	34	32	77	107	100
32	M16	4	29	131	214	180	102	167	140	54	89	75	170	278	233
40	M16	4	36,2	156	215	180	121	167	140	65	89	75	202	278	233
50	M16	4	45,3	176	220	193	137	171	150	73	91	80	228	285	250
65	M16	8	58,8	218	415	360	85	162	140	45	86	75	142	270	233
80	M16	8	72,4	244	452	360	95	176	140	51	94	75	158	293	233
100	M16	8	88,1	286	452	385	111	176	150	59	94	80	185	293	250
125	M16	8	101,2	336	452	385	131	176	150	70	94	80	218	293	250
150	M20	8	110,8	411	681	515	200	331	250	107	177	133	333	552	417
200	M20	12	128	538	859	772	174	278	250	93	148	133	290	463	417
250	M24	12	143,1	620	1010	781	238	388	300	127	207	160	397	647	500
300	M24	12	173,2	751	1467	1042	288	563	400	154	300	213	480	938	667
350	M24	16	164,8	1005	1830	1389	289	527	400	154	281	213	482	878	667
400	M27	16	176,1	1150	2023	1537	374	658	500	199	351	267	623	1097	833
450	M27	20	186,8	1458	2121	1729	379	552	450	202	294	240	632	920	750
500	M30	20	196,9	1751	2237	1875	514	656	550	274	350	293	857	1093	917
600	M33	20	310,5	2446	3168	2661	781	1012	850	417	540	453	1302	1687	1417
700	M33	24	319,6	2532	3310	2817	674	881	750	359	470	400	1123	1468	1250
800	M36	24	415,3	3271	3629	3316	947	1051	960	505	561	512	1578	1752	1600
900	M36	28	467,7	954	4371	3908	954	1085	970	509	579	517	1590	1808	1617
1000	M39	28	520,6	4243	5671	4848	1138	1521	1300	607	811	693	1897	2535	2167

## 8.14 Tabel 14: Leidingspecificatie A400, A401, A450 / PN40 – Vezelpakking

		Table 14													
Pipe class		A400, A401, A450													
Pipe system		PN40													
Flange Material		P250GH													
Bolt Material		25CrMo4 / 8.8													
Gasket Material		KLINGERSIL C-4400 2mm													
Gasket Manufacture		KLINGER® GmbH & Co. KG													
Gasket type		IBC													
Leak tightness		L0.01													
Friction		0,15													
Design pressure		According to the pipe class													
Design Temperature		200°C considered in the calculation													
External force and moments		DN15 -- DN600 = according EN1092 -1 (reduced)													

### Remarks

- Depending on lubrication, state of bolt and external forces the actual required torque may differ from the below advised calculated torque

- Afhankelijk van de smering, staat van de bouten en externe krachten kan het werkelijk benodigde aanhaalmoment afwijken van het hieronder berekende aanhaalmoment

Flange size (DN)	Bolt size	Number	External axial force (KN)	Bolt Force KN			Torque Nm								
				Min	Max	Used	Oil 0,15			Molycoat 0,08			No Lubrication 0,25		
							Min	Max	Used	Min	Max	Used	Min	Max	Used
15	M12	4	13,6												
20	M12	4	18,1	88	113	100	53	68	60	28	36	32	88	113	100
25	M12	4	22,6	83	107	100	50	64	60	27	34	32	83	107	100
32	M16	4	29	133	214	180	104	167	140	55	89	75	173	278	233
40	M16	4	36,2	158	216	180	123	168	140	66	90	75	205	280	233
50	M16	4	45,3	191	216	193	149	168	150	79	90	80	248	280	250
65	M16	8	58,8	227	443	385	88	172	150	47	92	80	147	287	250
80	M16	8	72,4	252	448	385	98	174	150	52	93	80	163	290	250
100	M20	8	88,1	338	680	515	164	330	250	87	176	133	273	550	417
125	M24	8	101,2	420	833	608	242	480	350	129	256	187	403	800	583
150	M24	8	110,8	487	1005	781	280	579	450	149	309	240	467	965	750
200	M27	12	128	739	1484	1153	321	644	500	171	343	267	535	1073	833
250	M30	12	143,1	971	2125	1636	475	1039	800	253	554	427	792	1732	1333
300	M30	16	152,5	1136	2690	2182	417	986	800	222	526	427	695	1643	1333
350	M33	16	164,8	1138	3241	2504	454	1294	1000	242	690	533	757	2157	1667
400	M36	16	180,5	1366	4304	3454	593	1869	1500	316	997	800	968	3115	2500
450	M36	20	230,6	1465	4706	4029	509	1635	1400	271	872	747	848	2725	2333
500	M39	20	291	1776	5445	3995	667	2044	1500	356	1090	800	1112	3407	2500
600	M45	20	394,4	2220	7390	5466	975	3245	2400	520	1731	1280	1625	5408	4000

### 8.15 Tabel 15: Leidingspecificatie F020, F022, H130 / PN10 – Vezelpakking

Pipe class	F020, F022, H130	<b>Table 15</b>				
Pipe system	PN10					
Flange Material	1.4404 / 1.4539 / 1.4571					
Bolt Material	A4-70					
Gasket Material	KLINGERSIL C-4400 2mm					
Gasket Manufacture	KLINGER® GmbH & Co. KG					
Gasket type	IBC					
Leak tightness	L0.01					
Friction	0,15					
Design pressure	According to the pipe class					
Design Temperature	200°C considered in the calculation					
External force and moments	DN15 – DN600 = according EN1092 -1 (reduced)					

#### Remarks

- Depending on lubrication, state of bolt and external forces the actual required torque may differ from the below advised calculated torque

- Afhankelijk van de smering, staat van de bouten en externe krachten kan het werkelijk benodigde aanhaalmoment afwijken van het hieronder berekende aanhaalmoment

Flange size (DN)	Bolt size	Number	External axial force (KN)	Bolt Force KN			Torque Nm								
				Min	Max	Used	Oil 0,15			Molycoat 0,08			No Lubrication 0,25		
							Min	Max	Used	Min	Max	Used	Min	Max	Used
15	M12	4	11,8	74	117	100	44	70	60	23	37	32	73	117	100
20	M12	4	15,7	76	117	100	45	70	60	24	37	32	75	117	100
25	M12	4	19,6	94	117	100	56	70	60	30	37	32	93	117	100
32	M16	4	25,1	112	227	193	87	177	150	46	94	80	145	295	250
40	M16	4	31,4	136	227	193	106	177	150	57	94	80	177	295	250
50	M16	4	39,3	159	227	193	124	177	150	66	94	80	207	295	250
65	M16	8	51,1	169	374	257	66	146	100	35	78	53	110	243	167
80	M16	8	62,9	203	462	385	79	180	150	42	96	80	132	300	250
100	M16	8	78,6	228	462	385	89	180	150	47	96	80	148	300	250
125	M16	8	87,8	274	462	385	107	180	150	57	96	80	178	300	250
150	M20	8	96,2	321	638	515	156	310	250	83	165	133	260	517	417
200	M20	8	111,1	392	711	515	190	345	250	101	184	133	317	575	417
250	M20	12	124,2	465	988	772	151	320	250	81	171	133	252	533	417
300	M20	12	136,1	550	1066	772	178	345	250	95	184	133	297	575	417
350	M20	16	147	814	1185	1029	198	288	250	106	154	133	330	480	417
400	M24	16	157,1	931	1337	1042	268	385	300	143	205	160	447	642	500
450	M24	20	166,7	1005	1388	1215	232	320	280	124	171	149	387	533	467
500	M24	20	175,7	1127	1481	1302	260	341	300	139	182	160	433	568	500
600	M27	20	192,5	1317	1705	1460	343	444	380	183	237	203	572	740	633

## 8.16 Tabel 16: Leidingspecificatie F210, F212 / PN16 – Vezelpakking

Pipe class	F210, F212	<b>Table 16</b>			
Pipe system	PN16				
Flange Material	1.4307 / 1.4571				
Bolt Material	A4-70				
Gasket Material	KLINGERSIL C-4400 2mm				
Gasket Manufacture	KLINGER® GmbH & Co. KG				
Gasket type	IBC				
Leak tightness	L0.01				
Friction	0,15				
Design pressure	According to the pipe class				
Design Temperature	200°C considered in the calculation				
External force and moments	DN15 -- DN600 = according EN1092 -1 (reduced)				

### Remarks

- Depending on lubrication, state of bolt and external forces the actual required torque may differ from the below advised calculated torque

- Afhankelijk van de smering, staat van de bouten en externe krachten kan het werkelijk benodigde aanhaalmoment afwijken van het hieronder berekende aanhaalmoment

Flange size (DN)	Bolt size	Number	External axial force (KN)	Bolt Force KN			Torque Nm								
				Min	Max	Used	Oil 0,15			Molycoat 0,08			No Lubrication 0,25		
							Min	Max	Used	Min	Max	Used	Min	Max	Used
15	M12	4	11,8												
20	M12	4	15,7	90	117	100	54	70	60	29	37	32	90	117	100
25	M12	4	19,6	86	117	100	51	70	60	27	37	32	85	117	100
32	M16	4	25,1	133	227	193	104	177	150	55	94	80	173	295	250
40	M16	4	31,4	155	227	193	121	177	150	65	94	80	202	295	250
50	M16	4	39,3	175	227	193	136	177	150	73	94	80	227	295	250
65	M16	8	51,1	235	371	308	91	144	120	49	77	64	152	240	200
80	M16	8	62,9	252	462	385	98	180	150	52	96	80	163	300	250
100	M16	8	78,6	304	462	385	118	180	150	63	96	80	197	300	250
125	M16	8	87,8	347	462	385	135	180	150	72	96	80	225	300	250
150	M20	8	96,2	420	626	515	204	304	250	109	162	133	340	507	417
200	M20	12	111,1	544	791	618	176	256	200	94	137	107	293	427	333
250	M24	12	124,2	601	931	781	231	357	300	123	190	160	385	595	500
300	M24	12	136,1	714	1277	781	274	490	300	146	261	160	457	817	500
350	M24	16	147	859	1762	1389	247	507	400	132	270	213	412	845	667
400	M27	16	157,1	961	1962	1537	313	638	500	167	340	267	522	1063	833
450	M27	20	166,7	1119	2070	1729	291	539	450	155	287	240	485	898	750
500	M30	20	175,7	1307	2207	1704	383	647	500	204	345	267	638	1078	833
600	M33	20	244	1783	2802	2191	570	895	700	304	477	373	950	1492	1167

## 8.17 Tabel 17: Leidingspecificatie F400, F401 / PN40 – Vezelpakking

Pipe class	F400, F401	<b>Table 17</b>				
Pipe system	PN40					
Flange Material	1.4404 / 1.4571					
Bolt Material	21CrMo5-7 / A4-70					
Gasket Material	KLINGERSIL C-4400 2mm					
Gasket Manufacture	KLINGER® GmbH & Co. KG					
Gasket type	IBC					
Leak tightness	L0.01					
Friction	0,15					
Design pressure	According to the pipe class					
Design Temperature	200°C considered in the calculation					
External force and moments	DN15 -- DN400 = according EN1092 -1 (reduced)					
<b>Remarks</b>						

- Depending on lubrication, state of bolt and external forces the actual required torque may differ from the below advised calculated torque

- Afhankelijk van de smering, staat van de bouten en externe krachten kan het werkelijk benodigde aanhaalmoment afwijken van het hieronder berekende aanhaalmoment

Flange size (DN)	Bolt size	Number	External axial force (KN)	Bolt Force KN			Torque Nm								
				Min	Max	Used	Oil 0,15			Molycoat 0,08			No Lubrication 0,25		
							Min	Max	Used	Min	Max	Used	Min	Max	Used
15	M12	4	11,8	50	136	100	30	81	60	16	43	32	50	135	100
20	M12	4	15,7	76	127	100	45	76	60	24	41	32	75	127	100
25	M12	4	19,6	68	122	100	41	73	60	22	39	32	68	122	100
32	M16	4	25,1	124	244	193	97	190	150	52	101	80	162	317	250
40	M16	4	31,4	150	246	193	117	192	150	62	102	80	195	320	250
50	M16	4	39,3	185	243	193	144	189	150	77	101	80	240	315	250
65	M16	8	19,7	184	441	385	72	172	150	38	92	80	120	287	250
80	M16	8	62,9	243	504	385	95	196	150	51	105	80	158	327	250
100	M20	8	78,6	320	550	412	155	267	200	83	142	107	258	445	333
125	M24	8	87,8	379	658	521	218	379	300	116	202	160	363	632	500
150	M24	8	96,2	450	839	608	259	483	350	138	258	187	432	805	583
200	M27	12	111,1	645	1155	922	280	501	400	149	267	213	467	835	667
250	M30	12	124,2	828	1681	1227	405	822	600	216	438	320	675	1370	1000
300	M30	16	136,1	1021	2171	1636	374	796	600	199	425	320	623	1327	1000
350	M33	16	160,4	1351	2839	2003	540	1134	800	288	605	427	900	1890	1333
400	M36	16	161	1832	3614	2533	796	1570	1100	425	837	587	1327	2617	1833

2.1

## 8.17 A Tabel 17a: Leidingspecificatie F400 / PN40 – Vezelpakking – Zuurstof systeem

Pipe class	F400	<b>Table 17a</b>			
Pipe system	PN40				
Flange Material	1.4404 / 1.4571				
Bolt Material	21CrMo5-7				
Gasket Material	KLINGERSIL C-4400 2mm				
Gasket Manufacture	KLINGER® GmbH & Co. KG				
Gasket type	IBC				
Leak tightness	L0.01				
Friction	0,15				
Design pressure	According to the pipe class				
Design Temperature	200°C considered in the calculation				
External force and moments	DN15 -- DN400 = according EN1092 -1 (reduced)				
<b>Remarks</b>					

- Depending on lubrication, state of bolt and external forces the actual required torque may differ from the below advised calculated torque

- Afhankelijk van de smering, staat van de bouten en externe krachten kan het werkelijk benodigde aanhaalmoment afwijken van het hieronder berekende aanhaalmoment

Flange size (DN)	Bolt size	Number	External axial force (KN)	Bolt Force KN			Torque Nm								
				Min	Max	Used	Berelub OX 40 EP 0,23			Berelub OX 100 EP 0,18			No Lubrication 0,25		
							Min	Max	Used	Min	Max	Used	Min	Max	Used
15	M12	4	11,8	50	136	100	46	124	92	36	97	72	50	135	100
20	M12	4	15,7	76	127	100	69	117	92	54	91	72	75	127	100
25	M12	4	19,6	68	122	100	63	112	92	49	88	72	68	122	100
32	M16	4	25,1	124	244	193	149	291	230	116	228	180	162	317	250
40	M16	4	31,4	150	246	193	179	294	230	140	230	180	195	320	250
50	M16	4	39,3	185	243	193	221	290	230	173	227	180	240	315	250
65	M16	8	19,7	184	441	385	110	264	230	86	206	180	120	287	250
80	M16	8	62,9	243	504	385	146	301	230	114	235	180	158	327	250
100	M20	8	78,6	320	550	412	238	409	307	186	320	240	258	445	333
125	M24	8	87,8	379	658	521	334	581	460	262	455	360	363	632	500
150	M24	8	96,2	450	839	608	397	741	537	311	580	420	432	805	583
200	M27	12	111,1	645	1155	922	429	768	613	336	601	480	467	835	667
250	M30	12	124,2	828	1681	1227	621	1260	920	486	986	720	675	1370	1000
300	M30	16	136,1	1021	2171	1636	573	1221	920	449	955	720	623	1327	1000
350	M33	16	160,4	1351	2839	2003	828	1739	1227	648	1361	960	900	1890	1333
400	M36	16	161	1832	3614	2533	1221	2407	1687	955	1884	1320	1327	2617	1833

2.1

## 8.17 B Tabel 17b: Leidingspecificatie F401 / PN40 – Vezelpakking – Zuurstof systeem

				F401	Table 17b											
Pipe class				PN40												
Pipe system				1.4404 / 1.4571												
Flange Material				A4-70												
Bolt Material				KLINGERSIL C-4400 2mm												
Gasket Material				KLINGER® GmbH & Co. KG												
Gasket Manufacture				IBC												
Gasket type				L0.01												
Leak tightness				0,15												
Friction				According to the pipe class												
Design pressure				200°C considered in the calculation												
Design Temperature																
External force and moments				DN15 -- DN400 = according EN1092 -1 (reduced)												
Remarks																
				- Depending on lubrication, state of bolt and external forces the actual required torque may differ from the below advised calculated torque												
				- Afhankelijk van de smering, staat van de bouten en externe krachten kan het werkelijk benodigde aanhaalmoment afwijken van het hieronder berekende aanhaalmoment												
Flange size (DN)	Bolt size	Number	External axial force (KN)	Bolt Force KN			Torque Nm									
				Min	Max	Used	Berelub OX 40 EP 0,26			Berelub OX 100 EP 0,26			No Lubrication 0,50			
							Min	Max	Used	Min	Max	Used	Min	max	used	
15	M12	4	11,8	50	136	100	52	140	104	52	140	104	100	270	200	
20	M12	4	15,7	76	127	100	78	132	104	78	132	104	150	253	200	
25	M12	4	19,6	68	122	100	71	127	104	71	127	104	137	243	200	
32	M16	4	25,1	124	244	193	168	329	260	168	329	260	323	633	500	
40	M16	4	31,4	150	246	193	203	333	260	203	333	260	390	640	500	
50	M16	4	39,3	185	243	193	250	328	260	250	328	260	480	630	500	
65	M16	8	19,7	184	441	385	125	298	260	125	298	260	240	573	500	
80	M16	8	62,9	243	504	385	165	340	260	165	340	260	317	653	500	
100	M20	8	78,6	320	550	412	269	463	347	269	463	347	517	890	667	
125	M24	8	87,8	379	658	521	378	657	520	378	657	520	727	1263	1000	
150	M24	8	96,2	450	839	608	449	837	607	449	837	607	863	1610	1167	
200	M27	12	111,1	645	1155	922	485	868	693	485	868	693	933	1670	1333	
250	M30	12	124,2	828	1681	1227	702	1425	1040	702	1425	1040	1350	2740	2000	
300	M30	16	136,1	1021	2171	1636	648	1380	1040	648	1380	1040	1247	2653	2000	
350	M33	16	160,4	1351	2839	2003	936	1966	1387	936	1966	1387	1800	3780	2667	
400	M36	16	161	1832	3614	2533	1380	2721	1907	1380	2721	1907	2653	5233	3667	

## 8.18 Tabel 18: Leidingspecificatie A060 / PN10 – PTFE-gebaseerde pakking

Pipe class			A060	Table 18											
Pipe system			PN10												
Flange Material			P250GH												
Bolt Material			25CrMo4												
Gasket Material			KLINGER® top-chem2000 2,0mm												
Gasket Manufacture			KLINGER® GmbH & Co. KG												
Gasket type			IBC												
Leak tightness			L0.01												
Friction			0,15												
Design pressure			According to the pipe class												
Design Temperature			200°C considered in the calculation												
External force and moments			DN15 -- DN350 = according EN1092 -1 (reduced) DN400 -DN500 - 1.35 times of internal pressure DN600 & above - 1 times of internal pressure												
<b>Remarks</b>															
- Depending on lubrication, state of bolt and external forces the actual required torque may differ from the below advised calculated torque															
- Afhankelijk van de smering, staat van de bouten en externe krachten kan het werkelijk benodigde aanhaalmoment afwijken van het hieronder berekende aanhaalmoment															
Flange size (DN)	Bolt size	Number	External axial force (KN)	Bolt Force KN			Torque Nm								
				Min	Max	Used	Oil 0,15 Molycoat 0,08			No Lubrication 0,25					
				Min	Max	Used	Min	Max	Used	Min	Max	Used	Min	Max	Used
15	M12	4	13,6												
20	M12	4	18,1	37	119	85	22	70	50	12	37	27	37	117	83
25	M12	4	22,6	48	117	85	28	68	50	15	36	27	47	113	83
32	M16	4	29	61	240	196	47	184	150	25	98	80	78	307	250
40	M16	4	36,2	77	239	196	59	183	150	31	98	80	98	305	250
50	M16	4	50	99	240	196	76	184	150	41	98	80	127	307	250
65	M16	8	58,8	161	485	392	62	184	150	33	98	80	103	307	250
80	M16	8	72,4	184	488	392	70	187	150	37	100	80	117	312	250
100	M16	8	100	258	488	392	99	187	150	53	100	80	165	312	250
125	M16	8	101,2	266	488	392	102	187	150	54	100	80	170	312	250
150	M20	8	122,5	354	695	515	172	338	250	92	180	133	287	563	417
200	M20	8	128	387	695	515	188	338	250	100	180	133	313	563	417
250	M20	12	143,1	470	1051	772	152	340	250	81	181	133	253	567	417
300	M20	12	156,8	556	1051	772	180	340	250	96	181	133	300	567	417
350	M20	16	169,3	827	1408	1029	201	342	250	107	182	133	335	570	417
400	M24	16	135,4	879	1719	1215	253	495	350	135	264	187	422	825	583
450	M24	20	170,5	1159	1733	1302	267	399	300	142	213	160	445	665	500
500	M24	20	227,5	1423	1786	1519	328	411	350	175	219	187	547	685	583
600	M27	20	196,8	1664	2098	1729	433	546	450	231	291	240	722	910	750
700	M27	24	203,9	1764	2671	2075	383	579	450	204	309	240	638	965	750
800	M30	24	298,1	2213	3095	2454	541	757	600	289	404	320	902	1262	1000
900	M30	28	335,2	2635	3998	3341	552	838	700	294	447	373	920	1397	1167
1000	M33	28	416,5	3159	4405	3506	721	1005	800	385	536	427	1202	1675	1333



## 8.19 Tabel 19: Leidingspecificatie F020, F022 / PN10 – PTFE-gebaseerde pakking

Pipe class			F020, F022			Table 19									
Pipe system			PN10												
Flange Material			1.4404 /1.4571												
Bolt Material			A4-70												
Gasket Material			KLINGER® top-chem2000 2,0mm												
Gasket Manufacture			KLINGER® GmbH & Co. KG												
Gasket type			IBC												
Leak tightness			L0.01												
Friction			0,15												
Design pressure			According to the pipe class												
Design Temperature			200°C considered in the calculation												
External force and moments			DN15 -- DN600 = according EN1092 -1 (reduced)												
<b>Remarks</b>															
- Depending on lubrication, state of bolt and external forces the actual required torque may differ from the below advised calculated torque															
- Afhankelijk van de smering, staat van de bouten en externe krachten kan het werkelijk benodigde aanhaalmoment afwijken van het hieronder berekende aanhaalmoment															
Flange size (DN)	Bolt size	Number	External axial force (KN)	Bolt Force KN			Torque Nm								
				Min	Max	Used	Oil 0,15			Molycoat 0,08			No Lubrication 0,25		
							Min	Max	Used	Min	Max	Used	Min	Max	Used
15	M12	4	11,8												
20	M12	4	15,7	38	117	100	23	70	60	12	37	32	38	117	100
25	M12	4	19,6	49	117	100	29	70	60	15	37	32	48	117	100
32	M16	4	25,1	62	227	193	48	177	150	26	94	80	80	295	250
40	M16	4	31,4	78	227	193	61	177	150	33	94	80	102	295	250
50	M16	4	39,3	100	227	193	78	177	150	42	94	80	130	295	250
65	M16	8	51,1	157	437	385	61	170	150	33	91	80	102	283	250
80	M16	8	62,9	186	462	385	72	180	150	38	96	80	120	300	250
100	M16	8	78,6	241	462	385	94	180	150	50	96	80	157	300	250
125	M16	8	87,8	269	462	385	105	180	150	56	96	80	175	300	250
150	M20	8	96,2	335	711	618	163	345	300	87	184	160	272	575	500
200	M20	8	111,1	393	711	618	191	345	300	102	184	160	318	575	500
250	M20	12	124,2	477	1075	926	154	348	300	82	186	160	257	580	500
300	M20	12	136,1	563	1075	926	182	348	300	97	186	160	303	580	500
350	M20	16	147	822	1363	1029	200	331	250	107	177	133	333	552	417
400	M24	16	157,1	977	1531	1215	281	441	350	150	235	187	468	735	583
450	M24	20	166,7	1051	1580	1302	242	364	300	129	194	160	403	607	500
500	M24	20	175,7	1174	1671	1302	270	385	300	144	205	160	450	642	500
600	M27	20	192,5	1364	1896	1729	355	493	450	189	263	240	592	822	750

## 8.20 Tabel 20: Leidingspecificatie F212 / PN16 – PTFE-gebaseerde pakking

Pipe class	F212	Table 20													
Pipe system	PN16														
Flange Material	1,4571														
Bolt Material	A4-70														
Gasket Material	KLINGER® top-chem2000 2,0mm														
Gasket Manufacture	KLINGER® GmbH & Co. KG														
Gasket type	IBC														
Leak tightness	L0.01														
Friction	0,15														
Design pressure	According to the pipe class														
Design Temperature	200°C considered in the calculation														
External force and moments	DN15 -- DN600 = according EN1092 -1 (reduced)														

### Remarks

- Depending on lubrication, state of bolt and external forces the actual required torque may differ from the below advised calculated torque

- Afhankelijk van de smering, staat van de bouten en externe krachten kan het werkelijk benodigde aanhaalmoment afwijken van het hieronder berekende aanhaalmoment

Flange size (DN)	Bolt size	Number	External axial force (KN)	Bolt Force KN			Torque Nm								
				Min	Max	Used	Oil 0,15			Molycoat 0,08			No Lubrication 0,25		
							Min	Max	Used	Min	Max	Used	Min	Max	Used
15	M12	4	11,8												
20	M12	4	15,7	52	117	100	31	70	60	17	37	32	52	117	100
25	M12	4	19,6	67	117	100	40	70	60	21	37	32	67	117	100
32	M16	4	25,1	83	227	193	65	177	150	35	94	80	108	295	250
40	M16	4	31,4	102	227	193	79	177	150	42	94	80	132	295	250
50	M16	4	39,3	126	227	193	98	177	150	52	94	80	163	295	250
65	M16	8	51,1	337	435	385	131	169	150	70	90	80	218	282	250
80	M16	8	62,9	267	462	385	104	180	150	55	96	80	173	300	250
100	M16	8	78,6	321	462	385	125	180	150	67	96	80	208	300	250
125	M16	8	87,8	358	462	385	139	180	150	74	96	80	232	300	250
150	M20	8	96,2	500	711	618	243	345	300	130	184	160	405	575	500
200	M20	12	111,1	619	953	772	200	309	250	107	165	133	333	515	417
250	M24	12	124,2	672	1098	912	258	422	350	138	225	187	430	703	583
300	M24	12	136,1	724	1462	1172	278	561	450	148	299	240	463	935	750
350	M24	16	147	870	1981	1563	251	570	450	134	304	240	418	950	750
400	M27	16	157,1	973	2186	1691	317	711	550	169	379	293	528	1185	917
450	M27	20	166,7	1130	2298	1921	294	598	500	157	319	267	490	997	833
500	M30	20	175,7	1338	2431	1875	393	713	550	210	380	293	655	1188	917
600	M33	20	244	1830	3053	2504	585	975	800	312	520	427	975	1625	1333

### 8.21 Tabel 21: Leidingspecificatie M120, M170, M190 / PN10 – Hypalon pakking

Tabel nog niet beschikbaar. Neem voor meer informatie contact op met de pakkingleverancier.

## 8.22 Tabel 22: Leidingspecificatie A060, A120, I010, F020, F022 / PN10 – Rubber pakking

			A060, A120, I010, F020, F022	Table 22												
Pipe class			A060, A120, I010, F020, F022													
Pipe system			PN10													
Flange Material			P250GH / 1.4404 / 1.4571													
Bolt Material			25CrMo4 / A4-70													
Gasket Material			NBR													
Gasket Manufacture			Eriks													
Gasket type			IBC													
Leak tightness			L0.01													
Friction			0,15													
Design pressure			5 bar (g)													
Design Temperature			75°C considered in the calculation													
External force and moments			DN15 - DN150 - 1.6 times of internal pressure DN200 -DN250 - 1.35 times of internal pressure DN300 & DN500 - 1 times of internal pressure DN600 & above -100KN													
<b>Remarks</b>																
- Depending on lubrication, state of bolt and external forces the actual required torque may differ from the below advised calculated torque																
- Afhankelijk van de smering, staat van de bouten en externe krachten kan het werkelijk benodigde aanhaalmoment afwijken van het hieronder berekende aanhaalmoment																
Flange size (DN)	Bolt size	Number	External axial force (KN)	Bolt Force KN			Torque Nm									
				Min	Max	Used	Oil 0,15			Molycoat 0,08			No Lubrication 0,25			
							Min	Max	Used	Min	Max	Used	Min	Max	Used	
15	M12	4	0,2	5	14	8	3	8	5	2	4	3	5	13	8	
20	M12	4	0,3	7	24	17	4	14	10	2	7	5	7	23	17	
25	M12	4	0,5	9	32	17	5	19	10	3	10	5	8	32	17	
32	M16	4	1,4	12	39	26	9	30	20	5	16	11	15	50	33	
40	M16	4	1,2	15	50	26	11	38	20	6	20	11	18	63	33	
50	M16	4	1,9	18	63	39	14	48	30	7	26	16	23	80	50	
65	M16	8	3,1	25	85	52	10	33	20	5	18	11	17	55	33	
80	M16	8	4,3	31	106	52	12	41	20	6	22	11	20	68	33	
100	M16	8	6,1	35	114	78	13	44	30	7	23	16	22	73	50	
125	M16	8	9,2	49	153	78	19	59	30	10	31	16	32	98	50	
150	M20	8	13,5	57	168	103	28	82	50	15	44	27	47	137	83	
200	M20	8	22,6	88	247	165	43	120	80	23	64	43	72	200	133	
250	M20	12	35,9	119	305	185	39	99	60	21	53	32	65	165	100	
300	M20	12	37,7	142	349	185	46	113	60	25	60	32	77	188	100	
350	M20	16	45,8	239	639	329	58	155	80	31	83	43	97	258	133	
400	M24	16	60,4	295	733	417	85	211	120	45	113	64	142	352	200	
450	M24	20	77	357	808	521	82	186	120	44	99	64	137	310	200	
500	M24	20	96	430	928	521	99	214	120	53	114	64	165	357	200	
600	M27	20	100	524	1071	615	136	279	160	73	149	85	227	465	267	
700	M27	24	100	689	1471	830	149	319	180	79	170	96	248	532	300	
800	M30	24	100	862	1748	962	211	427	240	113	228	128	352	712	400	
900	M30	28	100	1022	1914	1241	214	401	260	114	214	139	357	668	433	
1000	M33	28	100	1250	2214	1315	285	505	300	152	269	160	475	842	500	

## 8.23 Tabel 23: Leidingspecificatie A060, A120, A210, I010, I200 / PN10/16 – Rubber pakking

			Table 23													
Pipe class			A060, A120, I010, A210, I200													
Pipe system			PN10 / PN16													
Flange Material			P250GH													
Bolt Material			25CrMo4													
Gasket Material			G-ST-P/S EPDM 4,0mm													
Gasket Manufacture			Kroll + Ziller GmbH & Co.KG.													
Gasket type			IBC													
Leak tightness			L0.01													
Friction			0,15													
Design pressure			10 bar (g) or according to the pipe class													
Design Temperature			75°C considered in the calculation													
External force and moments			DN32 -- DN80 = 1.6 times internal pressure DN100 -DN250 - 1.35 times of internal pressure DN300 -DN450 - 1 times of internal pressure DN500 & above 150KN External force													
<b>Remarks</b>																
- Depending on lubrication, state of bolt and external forces the actual required torque may differ from the below advised calculated torque																
- Afhankelijk van de smering, staat van de bouten en externe krachten kan het werkelijk benodigde aanhaalmoment afwijken van het hieronder berekende aanhaalmoment																
Flange size (DN)	Bolt size	Number	External axial force (KN)	Bolt Force KN			Torque Nm									
				Min	Max	Used	Oil 0,15			Molycoat 0,08			No Lubrication 0,25			
							Min	Max	Used	Min	Max	Used	Min	Max	Used	
15	M12	4														
20	M12	4														
25	M12	4														
32	M16	4	1,4	27	120	65	21	92	50	11	49	27	35	153	83	
40	M16	4	1,9	34	152	65	26	116	50	14	62	27	43	193	83	
50	M16	4	3,1	42	190	78	32	145	60	17	77	32	53	242	100	
65	M16	8	5,2	58	239	131	22	91	50	12	49	27	37	152	83	
80	M16	8	7,1	72	287	131	28	110	50	15	59	27	47	183	83	
100	M16	8	12,2	86	323	157	33	124	60	18	66	32	55	207	100	
125	M16	8	15,3	117	399	209	45	153	80	24	82	43	75	255	133	
150	M20	8	26,9	143	450	247	69	219	120	37	117	64	115	365	200	
200	M20	8	39,8	219	630	309	106	306	150	57	163	80	177	510	250	
250	M20	12	59,7	297	756	463	96	245	150	51	131	80	160	408	250	
300	M20	12	62,5	355	872	463	115	282	150	61	150	80	192	470	250	
350	M20	16	80,6	519	1209	618	126	294	150	67	157	80	210	490	250	
400	M24	16	100,3	654	1333	764	188	384	220	100	205	117	313	640	367	
450	M24	20	126,3	813	1379	955	187	318	220	100	170	117	312	530	367	
500	M24	20	150	933	1500	1085	215	346	250	115	185	133	358	577	417	
600	M27	20	150	1153	1757	1268	300	457	330	160	244	176	500	762	550	
700	M27	24	150	1219	2268	1363	264	492	300	141	262	160	440	820	500	
800	M30	24	150	1539	2749	1718	376	672	420	201	358	224	627	1120	700	
900	M30	28	150	1806	3487	1909	378	731	400	202	390	213	630	1218	667	
1000	M33	28	150	2216	3826	2410	506	873	550	270	466	293	843	1455	917	

## 8.24 Tabel 24: Leidingspecificatie F020, F022, F212, H130 / PN10/16 – Rubber pakking

Pipe class			F020, F022, H130, F212	<b>Table 24</b>											
Pipe system			PN10 / PN16												
Flange Material			1.4404 / 1.4539 / 1.4571												
Bolt Material			A4-70												
Gasket Material			G-ST-P/S EPDM 4,0mm												
Gasket Manufacture			Kroll + Ziller GmbH & Co.KG.												
Gasket type			IBC												
Leak tightness			L0.01												
Friction			0,15												
Design pressure			10 bar (g) or according to the pipe class												
Design Temperature			75°C considered in the calculation												
External force and moments			DN32 -- DN80 = 1.6 times internal pressure DN100 -DN250 - 1.35 times of internal pressure DN300 -DN500 - 1 times of internal pressure DN600 150KN External force												
<b>Remarks</b>															
- Depending on lubrication, state of bolt and external forces the actual required torque may differ from the below advised calculated torque															
- Afhankelijk van de smering, staat van de bouten en externe krachten kan het werkelijk benodigde aanhaalmoment afwijken van het hieronder berekende aanhaalmoment															
Flange size (DN)	Bolt size	Number	External axial force (KN)	Bolt Force KN			Torque Nm								
				Min	Max	Used	Oil 0,15			Molycoat 0,08			No Lubrication 0,25		
							Min	Max	Used	Min	Max	Used	Min	Max	Used
15	M12	4													
20	M12	4													
25	M12	4													
32	M16	4	1,6	28	120	77	22	93	60	12	50	32	37	155	100
40	M16	4	2,2	35	152	77	27	118	60	14	63	32	45	197	100
50	M16	4	3,5	44	190	103	34	148	80	18	79	43	57	247	133
65	M16	8	5,8	60	240	128	23	93	50	12	50	27	38	155	83
80	M16	8	8	75	289	154	29	112	60	15	60	32	48	187	100
100	M16	8	11,3	86	317	154	33	123	60	18	66	32	55	205	100
125	M16	8	17,1	118	404	206	46	157	80	25	84	43	77	262	133
150	M20	8	25	141	443	247	69	215	120	37	115	64	115	358	200
200	M20	8	42	221	641	329	107	311	160	57	166	85	178	518	267
250	M20	12	67	299	781	432	97	253	140	52	135	75	162	422	233
300	M20	12	70	358	903	494	116	292	160	62	156	85	193	487	267
350	M20	16	83,3	524	1095	741	127	266	180	68	142	96	212	443	300
400	M24	16	93	615	1214	764	177	350	220	94	187	117	295	583	367
450	M24	20	100	664	1270	868	153	293	200	82	156	107	255	488	333
500	M24	20	124,5	801	1366	955	185	315	220	99	168	117	308	525	367
600	M27	20	150	944	1592	1230	246	414	320	131	221	171	410	690	533